

# EB46110

## Slotless BLDC Motor 空心杯無刷馬達

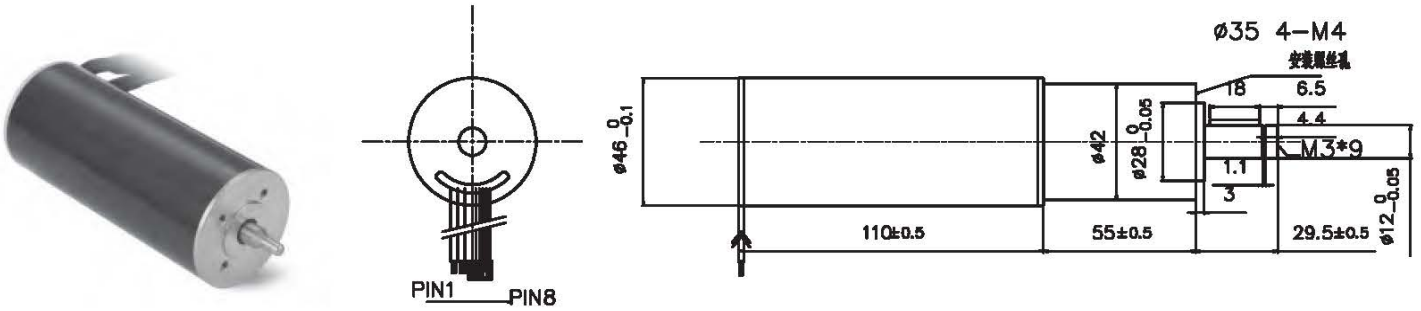

代表性用途 Typical Applications:  
伺服舵機、智能小機器人

馬達電氣特性表 ( Motor data )		01A			
額定電壓下數值 (Values at nominal voltage)					
1	額定電壓 (Nominal voltage)	v	24		
2	空載轉速 (No load speed)	rpm	8800		
3	空載電流 (No load current)	mA	1200		
4	額定轉速 (Nominal speed)	rpm	7656		
5	額定轉矩 (最大連續轉矩) (Nominal torque)	mNm	500		
6	額定電流 (最大連續電流) (Nominal current)	A	20.54		
7	堵轉轉矩 (Stall torque)	mNm	3829		
8	堵轉電流 (Stall current)	A	150		
9	最大效率 (Max efficiency)	%	84		
馬達常數 (Motor constant)					
10	相間電阻 (Terminal resistance)	Ω	0.16		
11	轉矩常數 (Torque constant)	mNm/A	25.53		
12	速度常數 (Speed constant)	rpm / V	367		

### 其它特性参数 Other characteristic parameters 特性曲線表

- 13 使用環境溫度範圍 (Ambient temperature) -10 - 40°C
- 14 線圈組最高容許溫度 (Max permissible winding temperature) 120°C
- 15 最高容許轉速 (Max permissible speed) 20000rpm
- 16 電極磁極對數 (Number of the pole pairs) 1
- 17 相數 (Number of pole pairs) 3
- 18 馬達重量 (Weight) 955g

端子定義：  
PIN1-PIN3 電機繞組  
1--3 PIN4 GND  
PIN5-PIN7 傳感器1--3  
PIN8 Vhall 2--18VDC

