

# EB3670 Slotless BLDC Motor 空心杯無刷馬達

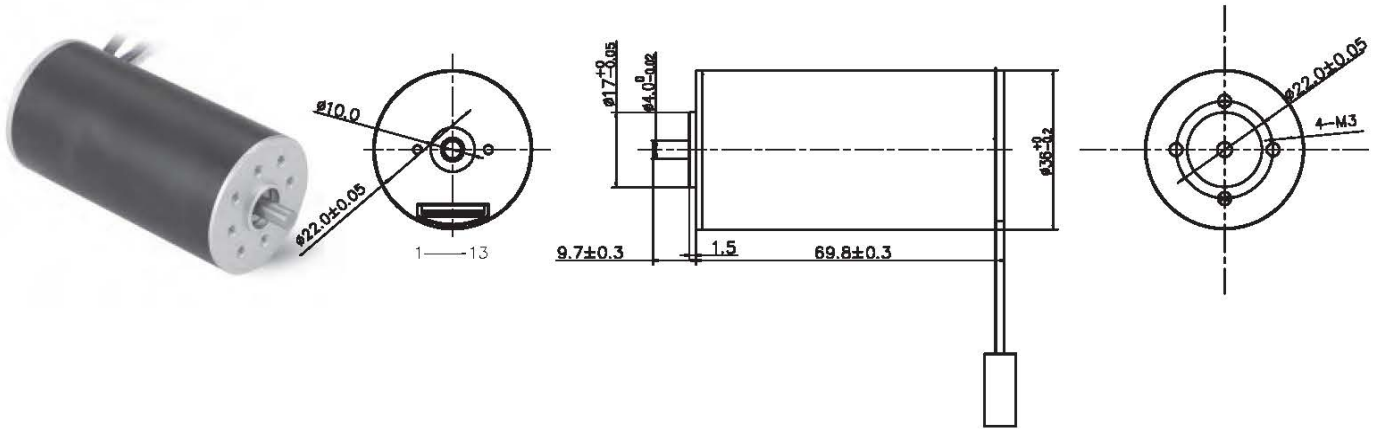

代表性用途 Typical Applications:  
伺服舵機、智能小機器人

馬達電氣特性表 ( Motor data )		02A	01A	04A		
額定電壓下數值 (Values at nominal voltage)						
1 額定電壓 (Nominal voltage)	v	24	24	30		
2 空載轉速 (No load speed)	rpm	11300	16700	12000		
3 空載電流 (No load current)	mA	540	1050	300		
4 額定轉速 (Nominal speed)	rpm	10396	14926	9960		
5 額定轉矩 (最大連續轉矩) (Nominal torque)	mNm	100	200	200		
6 額定電流 (最大連續電流) (Nominal current)	A	5.40	15.76	8.74		
7 堵轉轉矩 (Stall torque)	mNm	1223	1899	1170		
8 堵轉電流 (Stall current)	A	61.54	141.18	50.00		
9 最大效率 (Max efficiency)	%	83	84	86		
馬達常數 (Motor constant)						
10 相間電阻 (Terminal resistance)	Ω	0.39	0.17	0.60		
11 轉矩常數 (Torque constant)	mNm/A	19.89	13.46	23.40		
12 速度常數 (Speed constant)	rpm / V	471	696	400		

## 其它特性参数 Other characteristic parameters 特性曲線圖

- 13 使用環境溫度範圍 (Ambient temperature) -10 - 40°C
- 14 線圈組最高可容許溫度 (Max permissible winding temperature) 120°C
- 15 最高可容許轉速 (Max permissible speed) 20000rpm
- 16 電極磁極對數 (Number of the pole pairs) 1
- 17 相數 (Number of pole pairs) 3
- 18 馬達重量 (Weight) 314g

連接端子A: JST A2001H-6P PH2.0  
UL1332 PTEF AWG24  
1-VCC(black)、2-HA(black)、3-HB(black)、  
4-HC(black)、5-GND(black)  
連接端子B: VHR-3N PH3.96  
UI1430 AWG20 PVC  
6-MA(blue) 7-MB(black) 8-MC(white)  
連接端子線C: JST A2001H-5P PH2.0  
UI1332 AWG PTEF  
9-A(blue) 10-B(blue)  
11-I(blue) 12-Vcc(blue) 13-GND(blue)

