

EB1718 Slotless BLDC Motor 空心杯無刷馬達

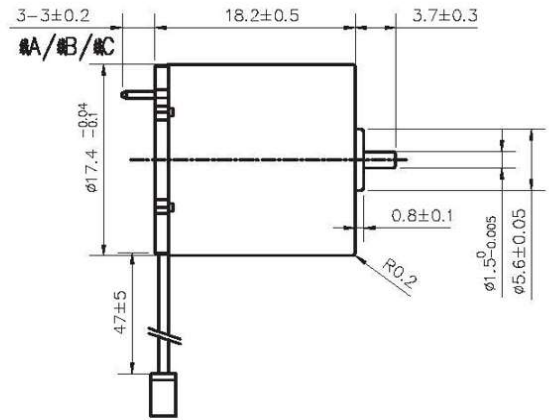
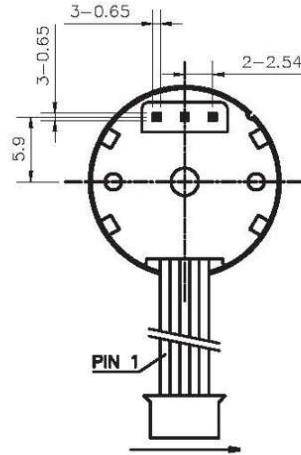

馬達電氣特性表 (Motor data)		46A	14A	51A	43A	50A	
額定電壓下數值(Values at nominal voltage)							
1	額定電壓(Nominal voltage)	V	6	7.4	8.4	12	12
2	空載轉速(No load speed)	rpm	17800	34910	32000	28000	24900
3	空載電流(No load current)	mA	116	224	220	150	110
4	額定轉速(Nominal speed)	rpm	16918	33339	24640	24920	21165
5	額定轉矩(最大連續轉矩)(Nominal Torque)	mNm	1	1	5	2	2
6	額定電流(最大連續電流) (Nominal current)	A	0.42	0.69	2.14	0.64	0.54
7	堵轉轉矩(Stall torque)	mNm	11.27	21.60	21.70	18.51	13.46
8	堵轉電流(Stall current)	A	3.57	10.88	8.57	4.62	2.99
9	最大效率(Max efficiency)	%	72	76	74	71	70
馬達常數(Motor constant)							
10	相間電阻(Terminal resistance)	Ω	1.68	0.68	0.98	2.60	4.02
11	轉矩常數(Torque constant)	mNm/A	3.16	1.98	2.46	4.01	4.51
12	速度常數(Speed constant)	rpm / V	2967	4718	3810	2333	2075

其他特性參數 Other characteristic parameters

- 13 使用環境溫度範圍 (Ambient temperature)
- 14 線圈組最高容許溫度 (Max permissible winding temperature)
- 15 最高容許轉速 (Max permissible speed)
- 16 電極磁極對數 (Number of the pole pairs)
- 17 相數 (Number of pole pairs)
- 18 馬達重量 (Weight)

端子定義:
 引線規格: 2651/28#
 PIN1 VCC
 PIN2 GND
 PIN3 Hall A
 PIN4 Hall B
 PIN5 Hall C

特性曲線表

