

FB50 Series (Φ50mm)

MOTOR FEATURE:

- RATED OUTPUT POWER : 15~40W
- RATED VOLTAGE : 12~24VDC
- OPERATIONAL SPEED :2500~ 3300RPM
- MAX. OUTPUT POWER : 120W
- Sleeve/Steel Ball bearing for option
- Replaceable Brush Type for option
- Pinion shaft or other requirement for option



Dimensions

(UNIT:mm)

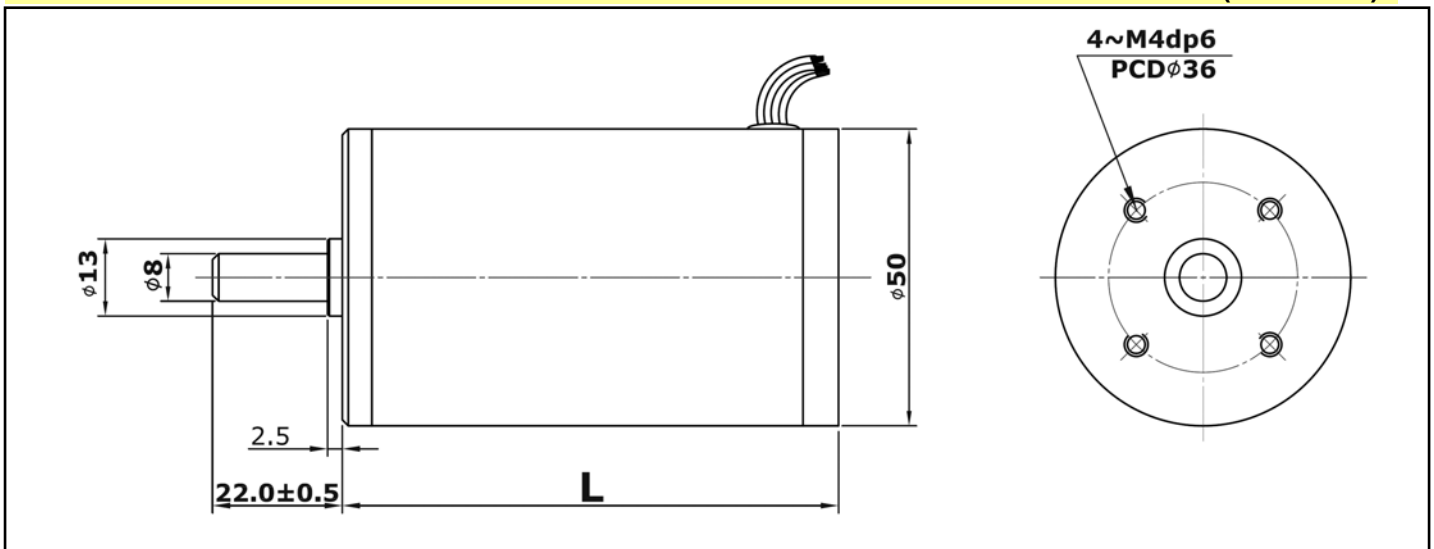

Typical Specifications (F =ferrite magnet, N= rare earth magnet)

MODEL	Rated						Weight (kg)	Length L (mm)
	Voltage (V)	Output (W)	Current (A)	Speed (RPM)	Torque (kgf-cm)	Rating		
FB50-N012020	12	17	1.98	2530	0.66	cont	0.77	84
FB50-N012030	12	26	3.0	3300	0.77	cont	0.77	84
FB50-N024025	24	22	1.27	2500	0.87	cont	0.77	84
FB50-N024035	24	34	1.82	3280	1.02	cont	0.77	84

- Pls discuss with us when you place an order non-standardized products such as voltage, speed and others.
- Mass production by standardizing the various types and manufacture the products with special size by order.
- Design or Motor spec. can be changed for quality improvement without any notice.

Copyright © 2012 Formosa Servo Electric Motor Co., Ltd./ EVERMO Group All Rights Reserved.