

FBG80 Series (□80mm)

MOTOR FEATURE:

- RATED OUTPUT POWER : 10~90W
- RATED VOLTAGE : 12~220VDC
- OPERATIONAL SPEED : 1~1000RPM
- MAX. OUTPUT POWER : 270W
- Sleeve/Steel Ball bearing for option
- Replaceable Brush Type for option
- Pinion shaft or other requirement for option



Dimensions

(UNIT:mm)

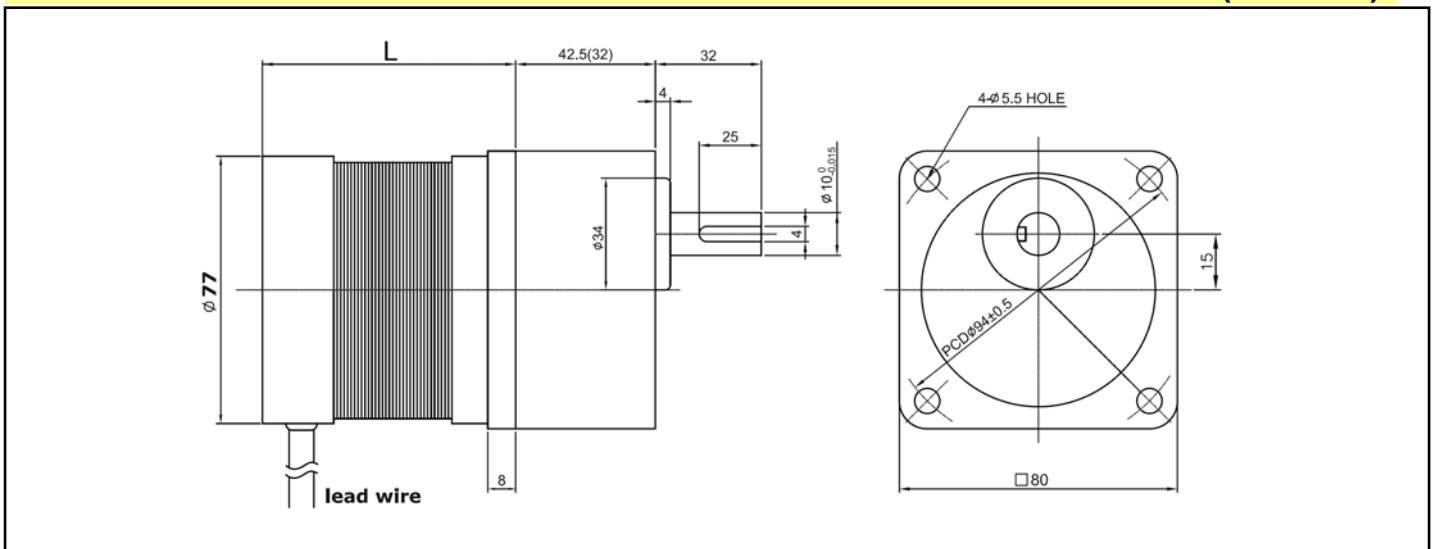

Typical Specifications (F =ferrite magnet, N= rare earth magnet)

MODEL	Rated						Weight (kg)	Length L (mm)
	Voltage (V)	Output (W)	Current (A)	Speed (RPM)	Torque (kgf-cm)	Rating		
FBG80-N012010	12	10	1.4	1~1000	0.99~80	cont	1.9	53
FBG80-N012015	12	15	2.1	1~1000	1.47~80	cont	2	63
FBG80-N012020	12	20	2.8	1~1000	1.95~80	cont	2.1	73
FBG80-N024015	24	15	1	1~1000	1.47~80	cont	1.9	53
FBG80-N024025	24	25	1.7	1~1000	9.9~80	cont	2	63
FBG80-N024035	24	35	2.4	1~1000	13.8~80	cont	2.1	73
FBG80-N220040	220	40	0.4	1~1000	3.9~80	cont	1.9	53
FBG80-N220060	220	60	0.5	1~1000	5.85~80	cont	2	63
FBG80-N220090	220	90	0.7	1~1000	8.7~80	cont	2.1	73

- Pls discuss with us when you place an order non-standardized products such as voltage, speed and others.
- Mass production by standardizing the various types and manufacture the products with special size by order.
- Design or Motor spec. can be changed for quality improvement without any notice.