

## FBD80C Series (□80mm)

### MOTOR FEATURE:

- RATED OUTPUT POWER : 40~50W
- RATED VOLTAGE : 24~220VDC
- OPERATIONAL SPEED : 2200~3000RPM
- MAX. OUTPUT POWER : 150W
- Sleeve/Steel Ball bearing for option
- Replaceable Brush Type for option
- Pinion shaft or other requirement for option



### Dimensions

(UNIT:mm)

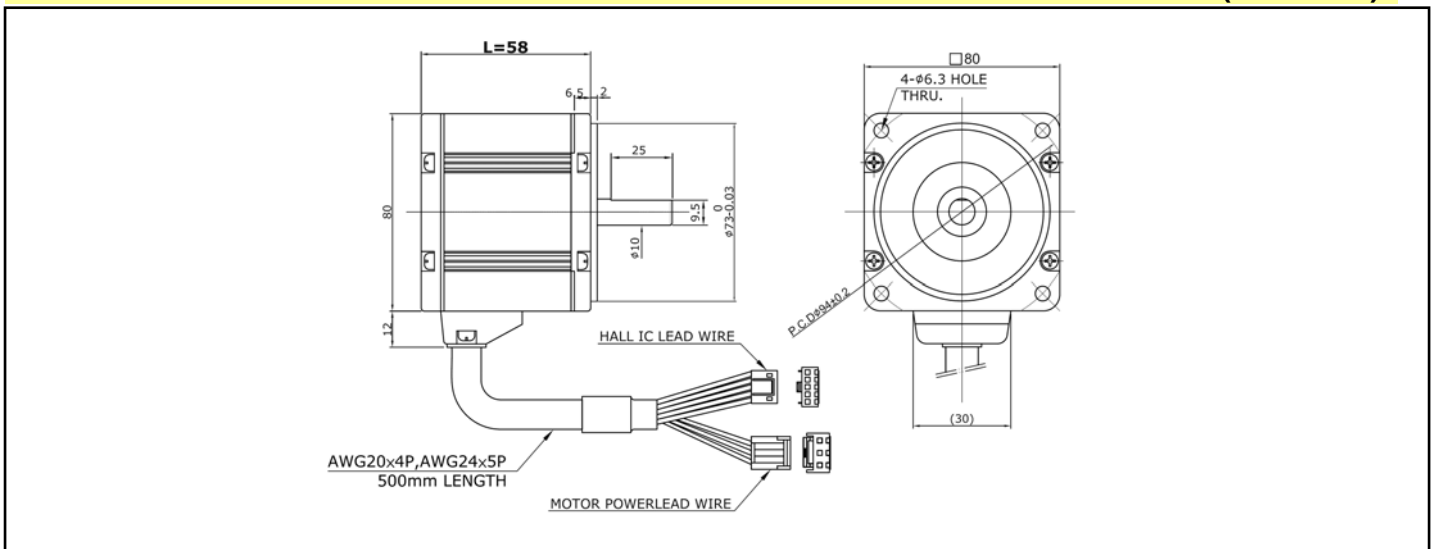

### Typical Specifications (F = ferrite magnet, N= rare earth magnet)

MODEL	Rated						Weight (kg)	Length L (mm)
	Voltage (V)	Output (W)	Current (A)	Speed (RPM)	Torque (kgf-cm)	Rating		
FBD80C-N024050	24	50	3.5	3000	1.63	cont	1.3	58
FBD80C-N220040	220	40	0.8	2200	1.95	cont	1.3	58
FBD80C-N220050	220	50	9.5	3000	1.63	cont	1.3	58

- Pls discuss with us when you place an order non-standardized products such as voltage, speed and others.
- Mass production by standardizing the various types and manufacture the products with special size by order.
- Design or Motor spec. can be changed for quality improvement without any notice.

Copyright © 2012 Formosa Servo Electric Motor Co., Ltd./ EVERMO Group All Rights Reserved.