

## FBE62 Series (Φ62 mm)

### MOTOR FEATURE:

- RATED OUTPUT POWER : 38W
- RATED VOLTAGE : 24VDC
- OPERATIONAL SPEED : 3000RPM
- MAX. OUTPUT POWER : 115W
- Sleeve/Steel Ball bearing for option
- Replaceable Brush Type for option
- Pinion shaft or other requirement for option



### Dimensions

(UNIT:mm)

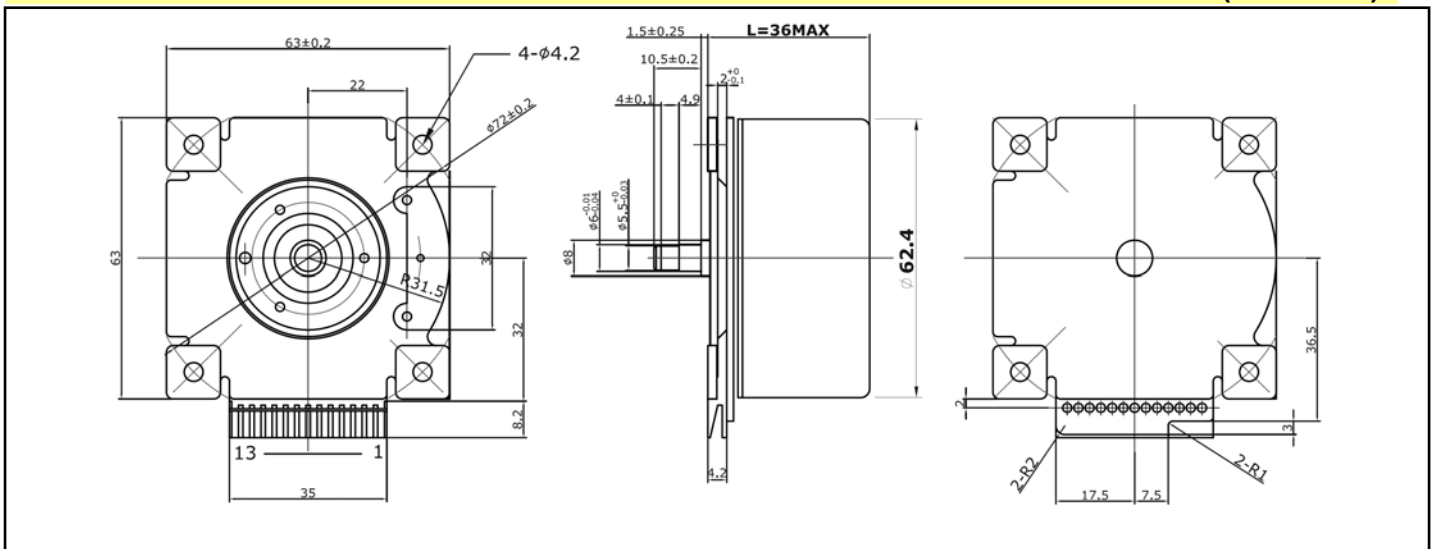

### Typical Specifications (F = ferrite magnet, N = rare earth magnet)

MODEL	Rated						Weight (kg)	Length L (mm)
	Voltage (V)	Output (W)	Current (A)	Speed (RPM)	Torque (kgf-cm)	Rating		
FB62-N012020	24	38	2.3	3000	1.23	cont	0.6	36

- Pls discuss with us when you place an order non-standardized products such as voltage, speed and others.
- Mass production by standardizing the various types and manufacture the products with special size by order.
- Design or Motor spec. can be changed for quality improvement without any notice.

Copyright © 2012 Formosa Servo Electric Motor Co., Ltd./ EVERMO Group All Rights Reserved.