

FB42 Series (Φ42 mm)

MOTOR FEATURE:

- RATED OUTPUT POWER : 10~100W
- RATED VOLTAGE : 24VDC
- OPERATIONAL SPEED : 2000~6000RPM
- MAX. OUTPUT POWER : 300W
- Sleeve/Steel Ball bearing for option
- Replaceable Brush Type for option
- Pinion shaft or other requirement for option



Dimensions

(UNIT:mm)

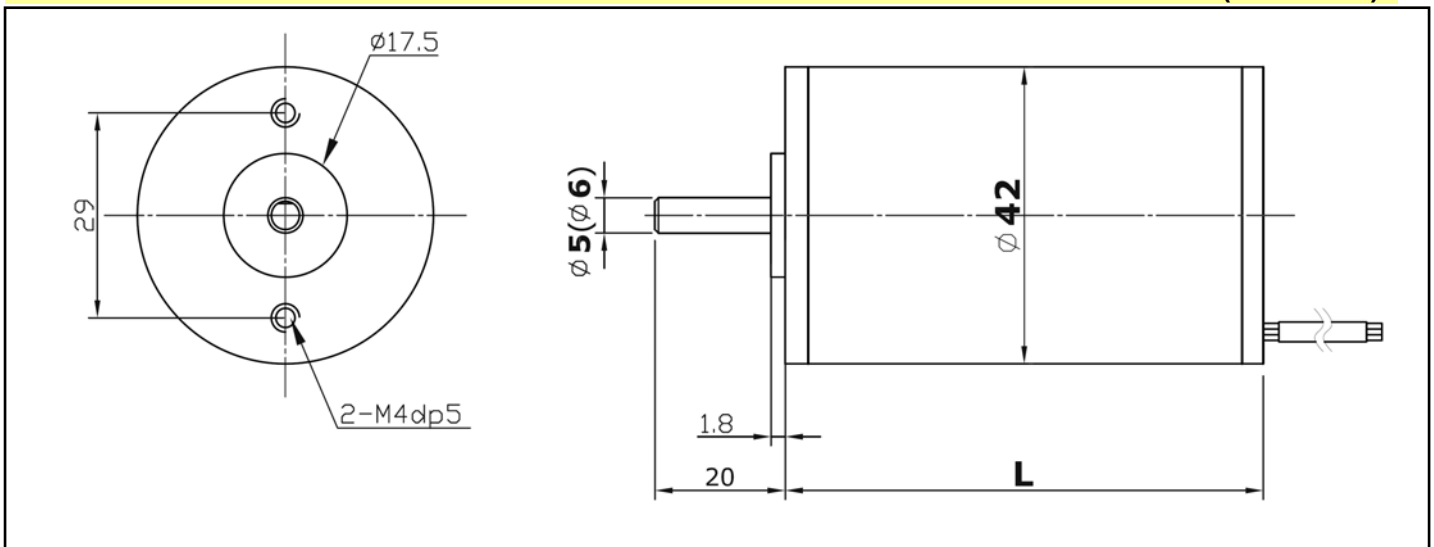

Typical Specifications (F=ferrite magnet, N= rare earth magnet)

MODEL	Rated						Weight (kg)	Length L (mm)
	Voltage (V)	Output (W)	Current (A)	Speed (RPM)	Torque (kgf-cm)	Rating		
FB42-N024010	24	8	0.53	2000	0.41	cont	0.37	43
FB42-N024017	24	17	1.0	4000	0.41	cont	0.37	43
FB42-N024025	24	25	1.42	6000	0.41	cont	0.37	43
FB42-N024020	24	21	1.06	2000	0.82	cont	0.46	54
FB42-N024040	24	42	1.86	4000	0.82	cont	0.46	54
FB42-N024060	24	63	2.75	6000	0.82	cont	0.46	54
FB42-N024030	24	33	2.13	2000	1.63	cont	0.63	73
FB42-N024070	24	67	3.72	4000	1.63	cont	0.63	73
FB42-N024100	24	100	5.51	6000	1.63	cont	0.63	73

- Pls discuss with us when you place an order non-standardized products such as voltage, speed and others.
- Mass production by standardizing the various types and manufacture the products with special size by order.
- Design or Motor spec. can be changed for quality improvement without any notice.