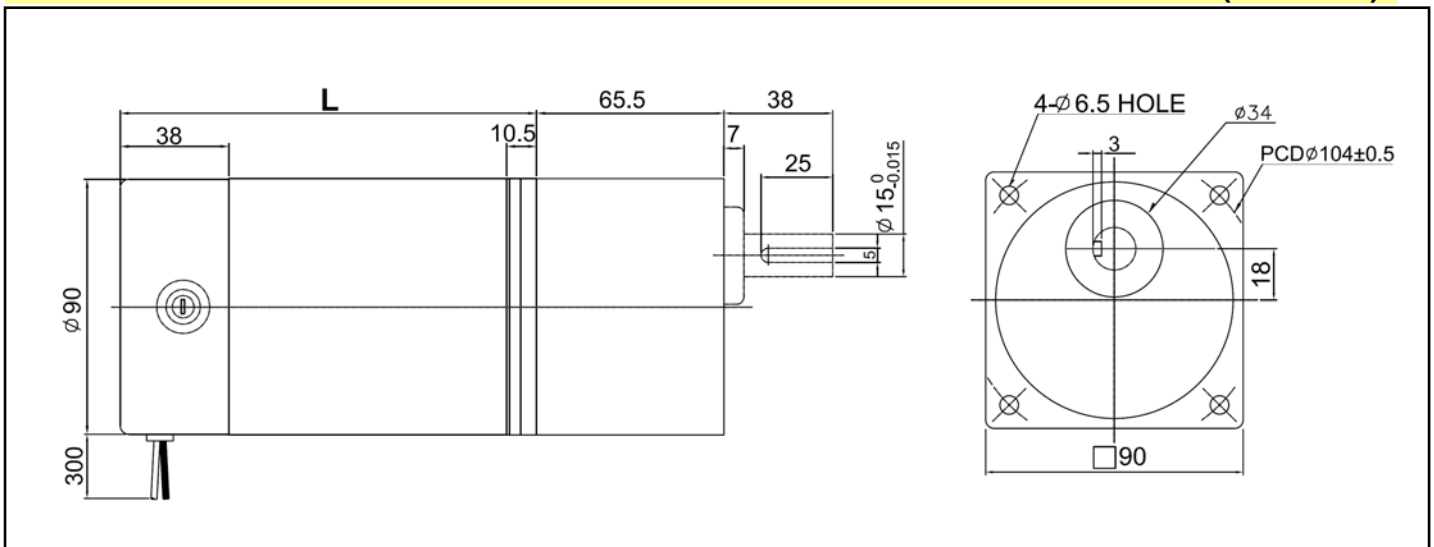

**FDG90K Series (□90mm)**
**MOTOR FEATURE:**

- RATED OUTPUT POWER : 60~500W
- RATED VOLTAGE : 12~180VDC
- OPERATIONAL SPEED : 1~1000RPM
- MAX. OUTPUT POWER : 1500W
- Sleeve/Steel Ball bearing for option
- Replaceable Brush Type for option
- Pinion shaft or other requirement for option

**Dimensions**
**(UNIT:mm)**

**Typical Specifications (F =ferrite magnet, N= rare earth magnet)**

MODEL	Rated						Weight (kg)	Length L (mm)
	Voltage (V)	Output (W)	Current (A)	Speed (RPM)	Torque (kgf-cm)	Rating		
FDG90K-F012060	12	60	6.7	1-1000	5.9~300	cont	4.2	145.5
FDG90K-F012090	12	90	10	1-1000	8.7~300	1hr	4.5	163.5
FDG90K-F012120	12	120	13.4	1-1000	11.7~300	1hr	4.9	188.5
FDG90K-F024060	24	60	3	1-1000	5.7~300	cont	3.9	120.5
FDG90K-F024090	24	90	5	1-1000	8.7~300	cont	4.2	145.5
FDG90K-F024150	24	150	8.3	1-1000	14.7~300	cont	4.9	188.5
FDG90K-F090090	90	90	1.3	1-1000	8.7~300	cont	3.9	120.5
FDG90K-F090120	90	120	1.8	1-1000	11.7~300	cont	4.2	145.5
FDG90K-F090200	90	200	3.2	1-1000	19.5~300	cont	4.5	163.5
FDG90K-F090300	90	300	4.5	1-1000	29.1~300	cont	4.9	188.5
FDG90K-F180120	180	120	0.95	1-1000	11.7~300	cont	3.9	120.5
FDG90K-F180200	180	200	1.5	1-1000	19.5~300	cont	4.2	145.5
FDG90K-F180300	180	300	2.3	1-1000	29.1~300	cont	4.5	163.5
FDG90K-F180500	180	500	3.7	1-1000	48.9~300	cont	4.9	188.5

- Pls discuss with us when you place an order non-standardized products such as voltage, speed and others.
- Mass production by standardizing the various types and manufacture the products with special size by order.
- Design or Motor spec. can be changed for quality improvement without any notice.