

FD110 Series (Φ110mm)

MOTOR FEATURE:

- RATED OUTPUT POWER : 300~600W
- RATED VOLTAGE : 24~180VDC
- OPERATIONAL SPEED : 1800~3600RPM
- MAX. OUTPUT POWER : 1800W
- Sleeve/Steel Ball bearing for option
- Replaceable Brush Type for option
- Pinion shaft or other requirement for option



Dimensions

(UNIT:mm)

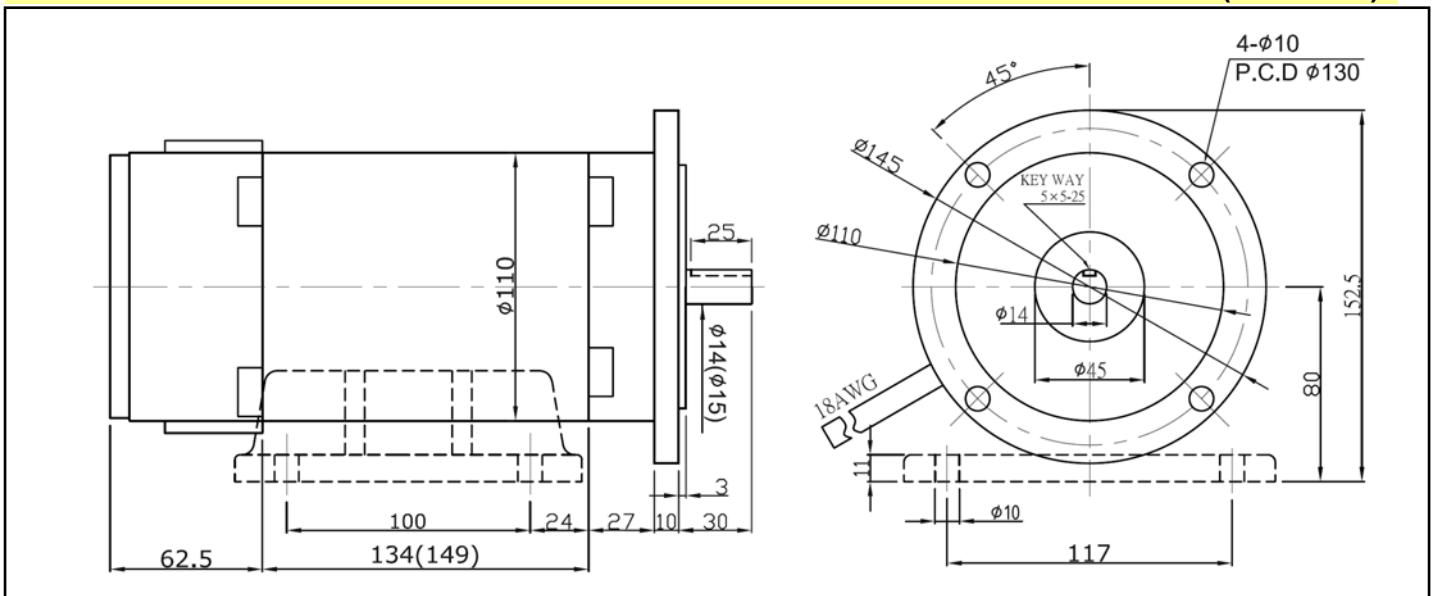

Typical Specifications (F = ferrite magnet, N= rare earth magnet)

MODEL	Rated						Weight (kg)	Length L (mm)
	Voltage (V)	Output (W)	Current (A)	Speed (RPM)	Torque (kgf-cm)	Rating		
FD110-F024400	24	400	22.5	3,000	13.0	cont	8.3	200
FD110-F090300	90	300	5	1,800	20.0	cont	8.3	200
FD110-F090600	90	600	15	3,600	20.0	cont	8.5	220
FD110-F180300	180	300	2.5	1,800	20.0	cont	8.3	200
FD110-F180600	180	600	5	3,600	20.0	cont	8.5	220

- Pls discuss with us when you place an order non-standardized products such as voltage, speed and others.
- Mass production by standardizing the various types and manufacture the products with special size by order.
- Design or Motor spec. can be changed for quality improvement without any notice.

Copyright © 2012 Formosa Servo Electric Motor Co., Ltd./ EVERMO Group All Rights Reserved.