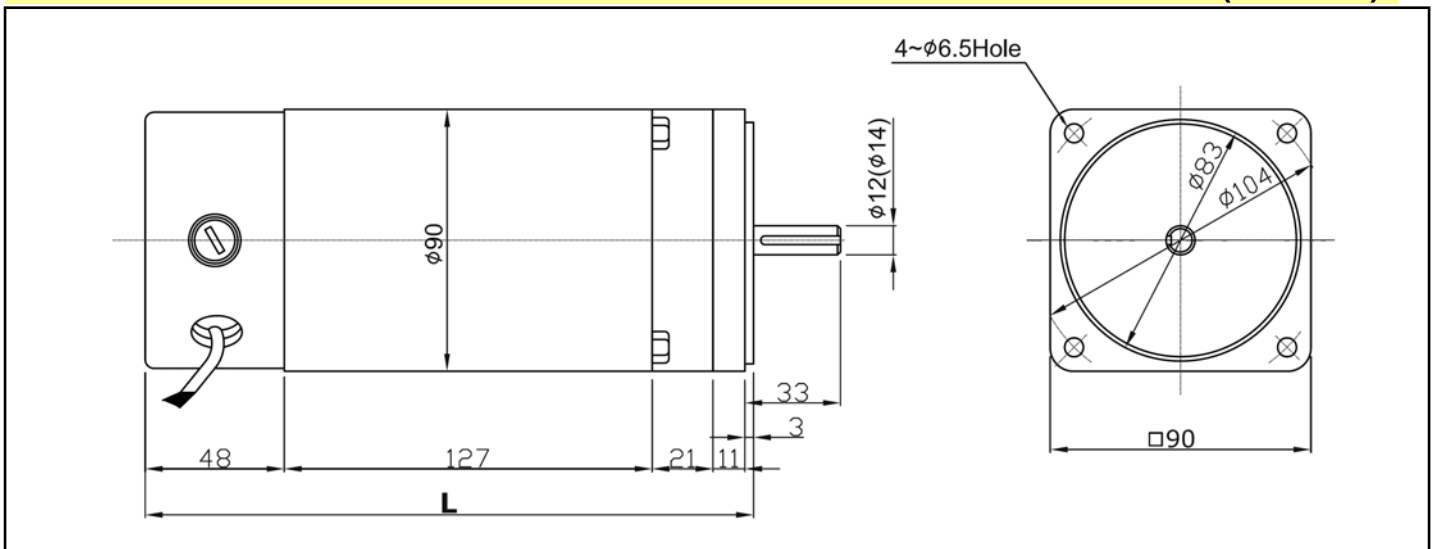

FD90P Series (□90mm)
MOTOR FEATURE:

- RATED OUTPUT POWER : 200~400W
- RATED VOLTAGE : 12~180VDC
- OPERATIONAL SPEED : 1800~3600RPM
- MAX. OUTPUT POWER : 1200W
- Sleeve/Steel Ball bearing for option
- Replaceable Brush Type for option
- Pinion shaft or other requirement for option

Dimensions

(UNIT:mm)

Typical Specifications (F = ferrite magnet, N= rare earth magnet)

MODEL	Rated						Weight (kg)	Length L (mm)
	Voltage (V)	Output (W)	Current (A)	Speed (RPM)	Torque (kgf-cm)	Rating		
FD90P-F012200	12	200	23	1,800	13	cont	4.3	210
FD90P-F024200	24	200	12	1,800	13	cont	4.3	210
FD90P-F090200	90	200	3	1,800	13	cont	4.3	210
FD90P-F180200	180	200	1.5	1,800	13	cont	4.3	210
FD90P-F024400	24	400	23.5	3,600	13	30 min.	4.3	210
FD90P-F090400	90	400	6	3,600	13	30 min.	4.3	210
FD90P-F180400	180	400	3	3,600	13	30 min.	4.3	210

- Pls discuss with us when you place an order non-standardized products such as voltage, speed and others.
- Mass production by standardizing the various types and manufacture the products with special size by order.
- Design or Motor spec. can be changed for quality improvement without any notice.

Copyright © 2012 Formosa Servo Electric Motor Co., Ltd./ EVERMO Group All Rights Reserved.