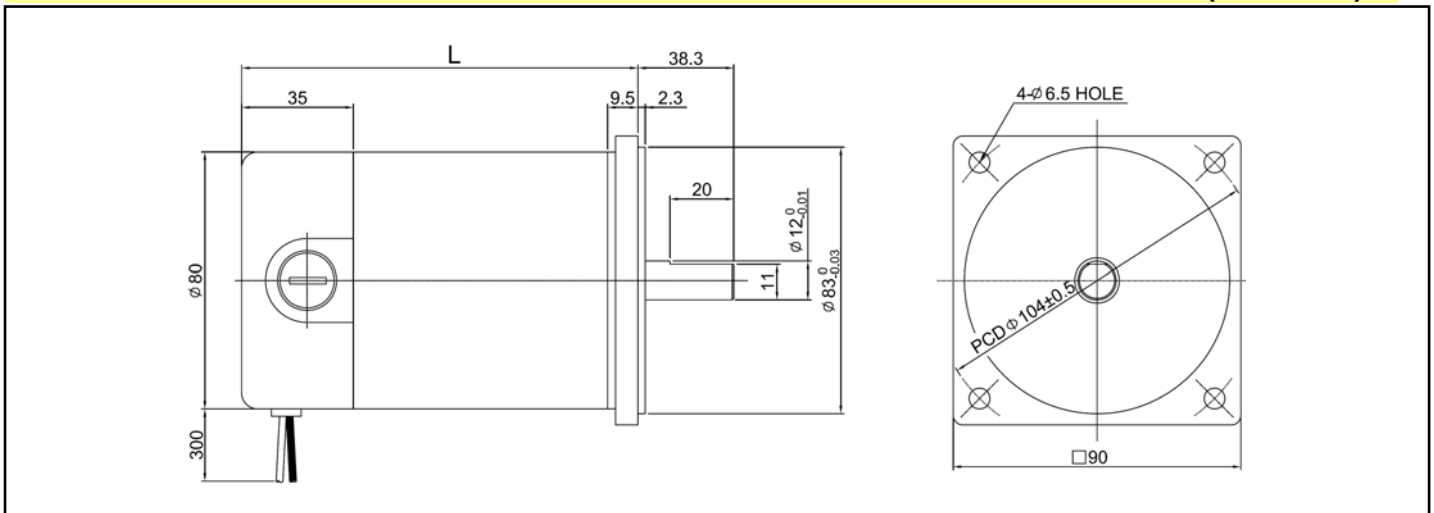

FD90 Series (□90mm)
MOTOR FEATURE:

- RATED OUTPUT POWER : 60~350W
- RATED VOLTAGE : 12~220VDC
- OPERATIONAL SPEED : 3000RPM
- MAX. OUTPUT POWER : 1050W
- Sleeve/Steel Ball bearing for option
- Replaceable Brush Type for option
- Pinion shaft or other requirement for option

Dimensions
(UNIT:mm)

Typical Specifications (F =ferrite magnet, N= rare earth magnet)

MODEL	Rated						Weight (kg)	Length L (mm)
	Voltage (V)	Output (W)	Current (A)	Speed (RPM)	Torque (kgf-cm)	Rating		
FD90-F012060	12	60	6.7	3,000	1.95	cont	2.9	159.5
FD90-F012090	12	90	10	3,000	2.9	1 hr	2.9	159.5
FD90-F012120	12	120	12.5	3,000	3.9	cont	3.2	184.5
FD90-F024090	24	90	5	3,000	2.9	cont	2.9	159.5
FD90-F024120	24	120	6.7	3,000	3.9	1 hr	2.9	159.5
FD90-F024200	24	200	10.4	3,000	6.5	1 hr	3.4	184.5
FD90-F090150	90	150	2.2	3,000	4.9	cont	3	159.5
FD90-F090200	90	200	3.3	3,000	6.5	cont	3.2	159.5
FD90-F090250	90	250	4	3,000	8	1 hr	3.4	184.5
FD90-F180300	180	300	2.5	3,000	9.7	cont	3.5	184.5
FD90-F220350	220	350	2.4	3,000	11	cont	3.7	184.5

- Pls discuss with us when you place an order non-standardized products such as voltage, speed and others.
- Mass production by standardizing the various types and manufacture the products with special size by order.
- Design or Motor spec. can be changed for quality improvement without any notice.