

FD80 Series (□80mm)

MOTOR FEATURE:

- RATED OUTPUT POWER : 10~120W
- RATED VOLTAGE : 12~220VDC
- OPERATIONAL SPEED : 3000RPM
- MAX. OUTPUT POWER : 360W
- Sleeve/Steel Ball bearing for option
- Replaceable Brush Type for option
- Pinion shaft or other requirement for option



Dimensions

(UNIT:mm)

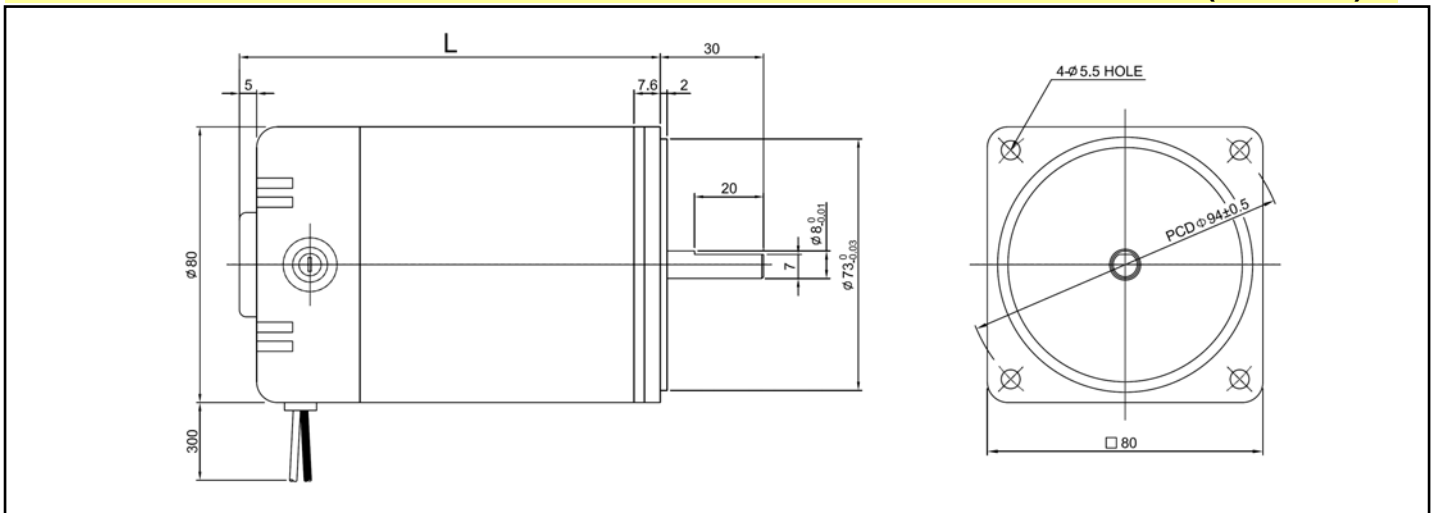

Typical Specifications (F = ferrite magnet, N= rare earth magnet)

MODEL	Rated						Weight (kg)	Length L (mm)
	Voltage (V)	Output (W)	Current (A)	Speed (RPM)	Torque (kgf-cm)	Rating		
FD80-F012010	12	10	1.1	3,000	0.33	cont	1.4	121.5
FD80-F012025	12	25	2.5	3,000	0.78	cont	1.5	121.5
FD80-F012040	12	40	4.2	3,000	1.3	cont	1.9	141.5
FD80-F024025	24	25	1.3	3,000	0.78	cont	1.5	121.5
FD80-F024035	24	35	2	3,000	1.15	cont	1.55	121.5
FD80-F024040	24	40	2	3,000	1.3	cont	1.9	141.5
FD80-F024060	24	60	3.2	3,000	1.9	cont	1.9	141.5
FD80-F090025	90	25	0.4	3,000	0.78	cont	1.5	121.5
FD80-F090040	90	40	0.8	3,000	1.3	cont	1.6	121.5
FD80-F090060	90	60	0.95	3,000	1.9	cont	1.9	141.5
FD80-F180050	180	50	0.4	3,000	1.62	cont	1.6	121.5
FD80-F180090	180	90	0.7	3,000	2.9	cont	2	141.5
FD80-F220060	220	60	0.4	3,000	1.95	cont	1.6	121.5
FD80-F220120	220	120	0.72	3,000	3.89	cont	1.9	141.5

- Pls discuss with us when you place an order non-standardized products such as voltage, speed and others.
- Mass production by standardizing the various types and manufacture the products with special size by order.
- Design or Motor spec. can be changed for quality improvement without any notice.