



ERS-770SH

EVERMO®
DC MICRO MOTOR
 Carbon-brush motors

OUTPUT :13W~115W (APPROX)

WEIGHT : 340g (APPROX)

Typical Applications **Cordless Power Tools:** Drill, Cordless Garden Tool, Circular Saw
Office Automation Equipment: Printer, Copy Machine

Typical Specifications

MODEL	VOLTAGE		NO LOAD		AT MAXIMUM EFFICIENCY						STALL		
	OPERATING RANGE	NOMINAL	SPEED r/min	CURRENT A	SPEED r/min	CURRENT A	TORQUE		OUTPUT W	EFF. %	TORQUE		CURRENT
							g.cm	mNm			A	g.cm	mNm
ERS770SH-8525F	6.0~12.0	12.0V CONSTANT	16000	1.80	13500	12.08	819	80.29	114.28	79.40	82.97	5997	587.94
ERS770SH-7040	6.0~18.0	12.0V CONSTANT	9700	1.30	8400	5.98	605	59.31	52.79	73.43	56.91	6076	595.69
ERS770SH-4087	12.0~24.0	12.0V CONSTANT	4550	0.60	3500	2.81	572	56.08	21.14	62.92	14.11	3408	334.12
ERS770SH-32165	12.0~36.0	24.0V CONSTANT	4650	0.22	3900	1.25	540	52.94	22.04	73.61	8.56	4050	397.06
ERS-770SH-7031R	6.0~12.0	12.0V CONSTANT	12000	1.13	10678	6.90	515	50.47	57.67	67.7	75.82	5502	539.20
ERS-770SH-40103R	6.0~12.0	12.0V CONSTANT	3800	0.21	3380	1.68	383	37.54	13.28	65.7	13.5	3450	338.1

◎NOTE: 1)Casing ring 2) Ring varister 3) Capacitor for options only.

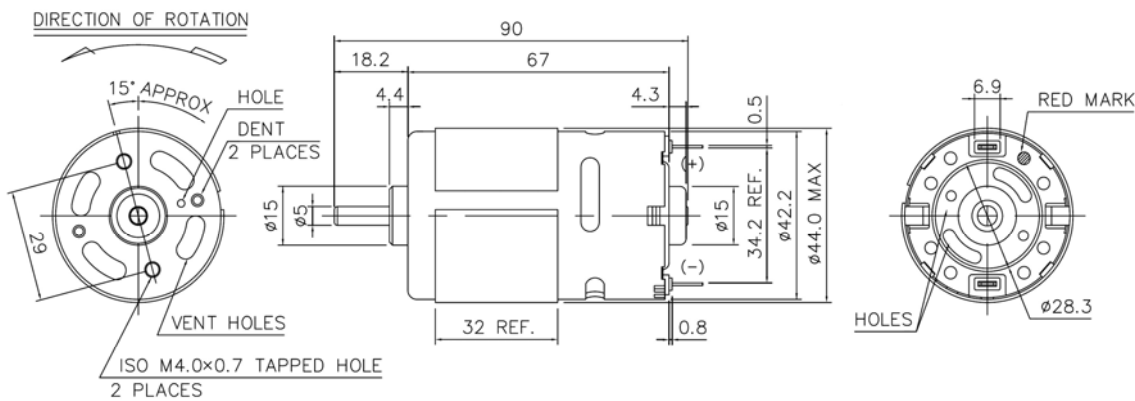

Usable male screw length 5.0 max from motor mounting surface.

WEIGHT: 320g (APPROX)

Usable machines screw length 4.0max from motor mounting surface.

UNIT: MILLIMETERS