



EFK-390/395SA

EVERMO®
DC MICRO MOTOR
Carbon-brush motors

OUTPUT :3.5W~8W (APPROX)

WEIGHT : 95g (APPROX)

- Typical Applications
- Automotive Products
 - Power Scissors
 - Exhaust Actuator
 - Window Lifer
 - Gearbox

Typical Specifications

MODEL	VOLTAGE		NO LOAD		AT MAXIMUM EFFICIENCY						STALL		
	OPERATING RANGE	NOMINAL	SPEED r/min	CURRENT A	SPEED r/min	CURRENT A	TORQUE g.cm	TORQUE mNm	OUTPUT W	EFF. %	TORQUE A	TORQUE g.cm	CURRENT mNm
EFK-390SA-VC2J2-18190	6.0~12.0	12.0V CONSTANT	4500	0.11	3608	0.45	89.2	8.75	3.31	61.9	1.8	450	44.1
EFK-390SA-VC2J2-19175	6.0~12.0	12.0V CONSTANT	4800	0.09	4087	0.49	77.2	7.57	3.54	55.3	2.8	520	51
EFK-395PA-VC2J2-17120	12.0~24.0	24.0V CONSTANT	7700	0.09	6562	0.52	118	11.57	7.96	63.8	3	800	78.4

◎NOTE: 1)Casing ring 2) Ring varister 3) Capacitor for options only.

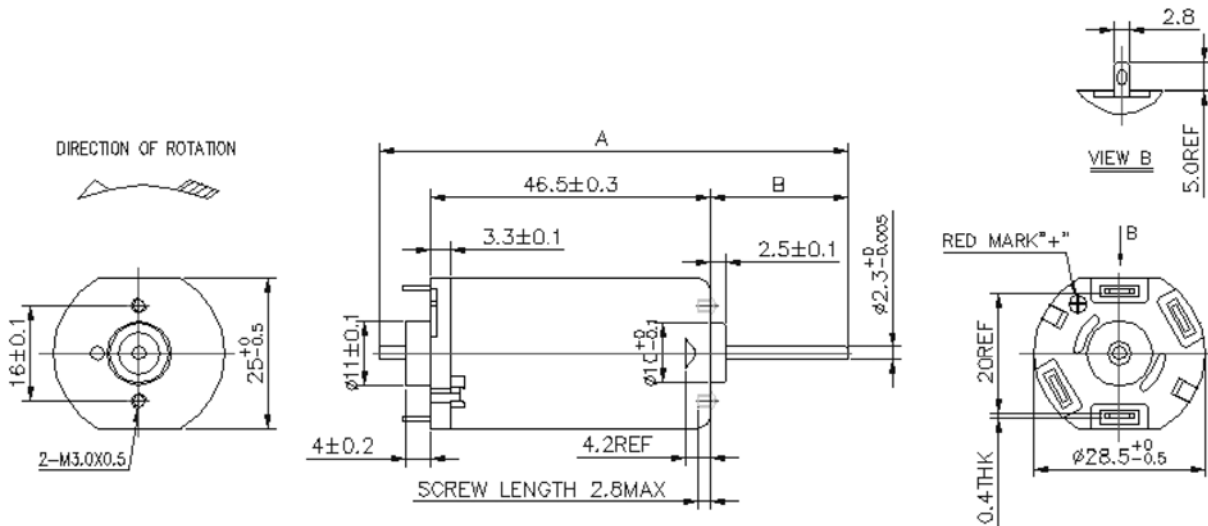

Usable machines screw length 4.0max from motor mounting surface.

UNIT: MILLIMETERS