



ERS-550SA

EVERMO®
DC MICRO MOTOR
 Carbon-brush motors

OUTPUT :3.7W~52W (APPROX)

WEIGHT : 210g (APPROX)

Typical Applications Home Appliances : Hair Dryer, Vending ,Geared Motor

Typical Specifications

MODEL	VOLTAGE		NO LOAD		AT MAXIMUM EFFICIENCY						STALL		
	OPERATING RANGE	NOMINAL	SPEED r/min	CURRENT A	SPEED r/min	CURRENT A	TORQUE g.cm	TORQUE mNm	OUTPUT W	EFF. %	TORQUE A	TORQUE g.cm	CURRENT mNm
ERS550SA-30100	12.0~24.0	12.0VCONSTANT	5200	0.30	4300	1.33	235	23.04	10.50	65	7.21	1500	147.06
ERS550SA-4553	6.0~12.0	12.0VCONSTANT	10200	0.60	8400	3.60	353	34.61	30.86	72	22.68	2513	246.37
ERS550SA-7521	4.8~12.0	7.2V CONSTANT	14500	1.50	12700	9.89	390	38.24	51.24	72	79.81	3680	353.73
ERS550SA-35110	6.0~24.0	12.0VCONSTANT	4500	0.15	3800	1.14	242	23.73	9.61	71	8.33	2020	198.04
ERS-550SA-28160	4.8~9.6	9.6V CONSTANT	2550	0.12	2212	0.51	162.0	15.88	3.66	74.5	3.15	1130	110.74
ERS-550SA-23128R	12.0~24.0	24.0V CONSTANT	4500	0.10	3932	0.69	262	25.68	10.6	63.7	4.8	2080	203.84

◎NOTE: 1)Casing ring 2) Ring varister 3) Capacitor for options only.

DIRECTION OF ROTATION

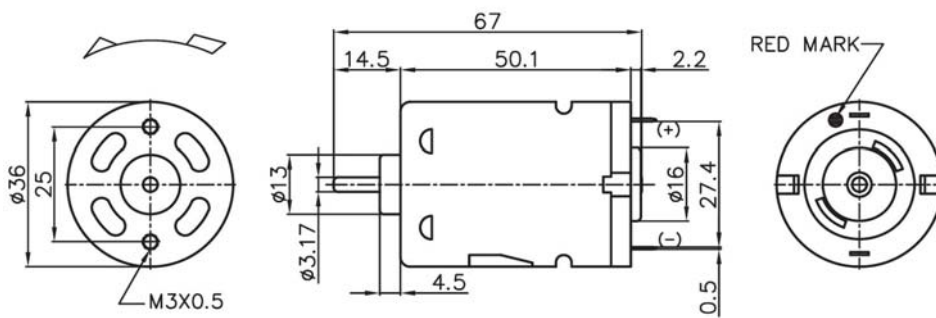

Usable machines screw length 4.0max.from motor mounting surface.

UNIT:MILLIMETERS